

Latest News!

TorqLOC

Edition

10/2003





SEW-EURODRIVE





1	Product Description	4
2	Functional Principle	5
3	Your benefits	6
	3.1 Quick and easy assembly and disassembly	6
	3.2 Cost reduction.....	7
	3.3 Versatile	7
4	Technical Data	8
	4.1 All type sizes at a glance	8
	4.2 Design versions	9
	4.3 Materials used.....	10
	4.4 NOCO-FLUID®	10
	4.5 Part numbers for rated diameter, standard type	11
	4.6 Part numbers for rated diameter, stainless type	12
	4.7 Different diameters.....	13
	4.8 Bushings in mm dimensions	14
	4.9 Bushings in inch dimensions.....	15
5	Installation notes	16
	5.1 Delivery condition.....	16
	5.2 Use in existing systems	16
	5.3 Assembly instructions	17
6	Applications	19
7	Clamping Joint for Bearings and Other Shaft/Hub Connections	20
8	Dimension sheets for gear units with TorqLOC clamping joint	21
	8.1 CAD drawings	21
	8.2 Dimension sheet for helical-bevel gear units with TorqLOC (KT..)	22
	8.3 Dimension sheet for parallel shaft helical gear units with TorqLOC (FT..)	23
	8.4 Dimension sheet for helical-worm gear units with TorqLOC (ST..).....	24
9	Documentation	25
10	Awards	26

1 Product Description

The patented TorqLOC hollow shaft mounting system is an alternative to conventional connection techniques such as keys or shrink discs.

The user not only benefits from straightforward installation and the possibility of safe disassembly even after many hours of operation, but also from a reduction in machining costs because the customer's shaft can be produced using drawn, unprocessed material.



Figure 1: TorqLOC

52312AXX



Figure 2: TorqLOC

52313AXX

2 Functional Principle

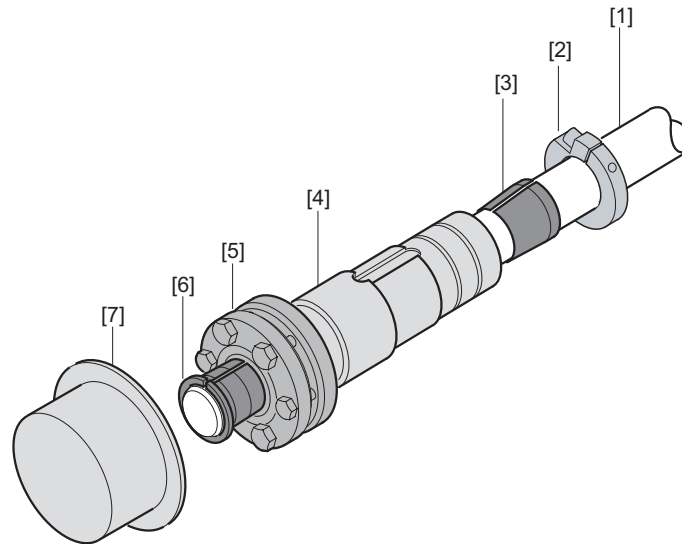

52314AXX

Figure 3: TorqLOC

- | | | |
|----------------------------|-------------------------------|---------------------------|
| [1] Customer's shaft | [4] Hollow shaft in gear unit | [6] Conical steel bushing |
| [2] Clamping ring | [5] Shrink disc | [7] Cover |
| [3] Conical bronze bushing | | |

TorqLOC is a non-positive clamping joint that functions similarly to the classic shrink disc connection. In addition to the hollow shaft, which is rigidly installed in the gear unit, the system consists of a special shrink disc, a clamping ring and two conical bushings that are inserted into both sides of the hollow shaft.

For installation, the clamping ring [2] is first pushed onto the customer's shaft, followed by the bronze bushing [3]. The gear unit is then mounted onto the customer's shaft. The axial position of the gear unit is determined by the torque arm. Mounting is possible without calibration or the need to apply force because no interference fits have to be overcome between the hollow shaft [4] and the input shaft. The bronze bushing is inserted into the hollow shaft and secured with the clamping ring [2]. Next, the shrink disc [5] and the conical steel counter-bushing [6] are inserted. The gearmotor is mounted on the input shaft once the shrink disc has been tightened. A fixed metal cover [7] provides protection against touching the rotating shrink disc and makes a further contribution towards accident prevention.

If dismantling is required, the procedure is performed in reverse order of installation. The special shrink disc [5] has three threaded holes which can be used for forcing it off. All the screws must be removed from the shrink disc and then three bolts screwed into the threads. The two discs of the shrink disc are forced apart. The shrink disc is forced out of the hollow shaft of the gear unit by means of the collar on the conical steel bushing [6]. The gearmotor is then already half dismantled from the customer's shaft. "Fretting corrosion" between the hollow shaft and the customer's shaft can no longer occur with TorqLOC because there are no interference fits to be overcome during disassembly either. In other connection systems such as keys or the conventional shrink disc, even the smallest metal chip or incipient corrosion would scuff the material during disassembly, therefore rendering disassembly increasingly difficult or even impossible.

**3 Your benefits****3.1 Quick and easy assembly and disassembly**

Classic shaft mounted gear units with hollow shafts and keys or with hollow shafts and shrink discs are becoming increasingly popular among users.

Although this type of gear unit offers many advantages, the narrow fit tolerances between the hollow shaft and the customer's shaft when installing gearmotors can be very complicated to achieve and require exact calibration.

Things also become difficult when the drive has to be removed from the input shaft due to a machine breakdown or for routine maintenance work. Despite every precaution, fretting corrosion may have occurred between the hollow shaft and the customer's shaft after a lengthy period of operation, for instance as a result of micro movements. This can make it very difficult and often exceedingly time-consuming to remove the gear unit from the customer's shaft.

The TorqLOC hollow shaft mounting system now represents an alternative to the conventional hollow shaft and shrink disc, as well as to the shaft-mounted type with a key. The patented clamping joint makes it significantly easier to install and remove the gear unit.

- No need to overcome tight-tolerance fits
- No complicated calibration
- Fretting corrosion is prevented to a considerable extent

Installation is very straightforward and the unit can be dismantled easily even after a long period of time and many operating hours. These advantages are particularly apparent during servicing or maintenance.

- Cost savings due to reduced installation times
- Reduction in maintenance work and downtime
- Increased machine serviceability

3.2 Cost reduction

because the customer's shaft is made from drawn material

In classic shaft-mounted gear units with a hollow shaft and key or a hollow shaft and shrink disc, manufacturing the customer's input shaft is relatively costly for the user because of the necessary keyway or fitting tolerances (normally quality h6). The conical bushings on both ends of the TorqLOC hollow shaft make it possible to adjust the tolerance on the customer's shaft by as much as 0.19 mm. This means drawn bar stock up to quality h11 can be used to produce the customer's shaft.

- Tolerance adjustment depending on diameter, up to 0.19 mm
- No keyways or interference fits required
- Drawn material can be used

By using a TorqLOC gearmotor and drawn bar stock for the input shaft, it is possible to dispense with machining the input shaft entirely, thus saving time and machining costs.

- Cost savings by using drawn bar stock of quality h11
- Low machining costs for the input shaft
- Reduction in manufacturing costs for the machine

3.3 Versatile

due to different shaft diameters

In classic shaft mounted gear units with hollow shafts and keys or with hollow shafts and shrink discs, the output shaft diameter cannot be changed once the drive has been ordered. The drive can only be used for the shaft diameter which has been specified in advance.

With the patented TorqLOC system, it is possible to adapt to other diameters with one and the same hollow shaft, as well as to use the rated diameters provided for the gear unit size. This allows for greater flexibility in operation and means that drive units can be standardized. All that is required is to change the conical bushings in the TorqLOC system. Starting from the rated diameter, shaft diameters down to rated minus 5 mm can be achieved by using different bushings. This makes it possible to adapt to different shaft diameters in a straightforward and inexpensive way.

- Adapting to different diameters with one gear unit type
- Conversion between metric and inch sizes is possible
- The conical bushings can easily be exchanged

By using different bushings, it is now possible to use one stocked gear unit type to cover several different shaft dimensions. This saves storage space and minimizes warehouse costs. When an old gearmotor is replaced in an existing machine, the new gearmotor can be adapted to the shaft diameter in the existing machine without the time and expense of converting the customer's shaft.

- Standardization of gear unit types
- Flexible use of drives in different machines
- Reduction in storage costs



4 Technical Data

4.1 All type sizes at a glance

The innovative TorqLOC is available for helical-worm, helical-bevel and parallel shaft helical gearmotors of sizes 37 to 97 and can therefore be used in an output torque range of 92 to 4300 Nm. There are no fundamental restrictions as far as the selection of gear ratios or options for the gearmotor is concerned. In the case of parallel shaft helical gear units, however, the maximum motor size is limited in some cases due to the fixed shrink disc cover.

Please refer to the dimension sheet notes in this regard.

Gear units	Type	Standard shaft diameter [mm]	M _{a max} [Nm]
Helical-worm gear units	ST37	20	92
	ST47	30	170
	ST57	35	295
	ST67	40	520
	ST77	50	1270
	ST87	65	2280
	ST97	75	4000
Parallel shaft helical gear unit	FT37	30	200
	FT47	35	400
	FT57	40	600
	FT67	40	820
	FT77	50	1500
	FT87	65	3000
	FT97	75	4300
Helical-bevel gear unit	KT37	30	200
	KT47	35	400
	KT57	40	600
	KT67	40	820
	KT77	50	1550
	KT87	65	2700
	KT97	75	4300

As torque support options, torque arms (/T) are available for helical-worm and helical-bevel gear units while rubber buffers (/G) are available for parallel shaft helical gear units.

Types KTF..., KTZ..., KT..B, and FTF...; FTZ..., FT..B, or STF..., STZ.. are **not** available!

Due to the fixed flange or foot mounting, stress could build up in the driveline because of the possible tolerance adjustment of the TorqLOC shaft. Furthermore, the clamping ring could not be mounted on flange-mounted types.

4.2 Design versions

TorqLOC:

The standard TorqLOC type has the shrink disc installed opposite the output end. This means the customer has to specify which is the output end when ordering. In helical-worm or right-angle gear units with TorqLOC, it is therefore necessary to stipulate whether the A or B end is the output end. In the figure, the A end is the output end. The shrink disc is located opposite to the output end.

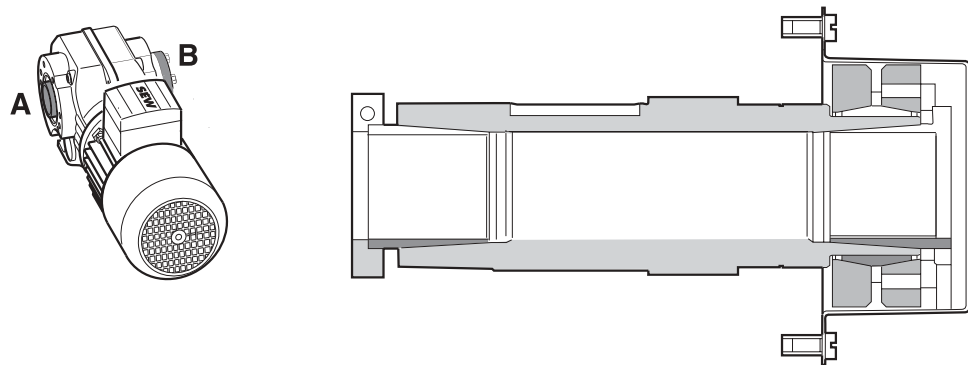

52309AXX

Figure 4: Design versions

TorqLOC Plus:

Apart from the standard version, a hollow shaft with a shrink disc seat on both ends is available on request. This means the customer has a free choice of output end. When ordering the TorqLOC Plus version, the output end must be specified as AB. TorqLOC Plus is not a standard version and may require an extended delivery time.

TorqLOC is slightly longer than the standard version. As a result, a corresponding amount of extra space must be provided in the customer's design.

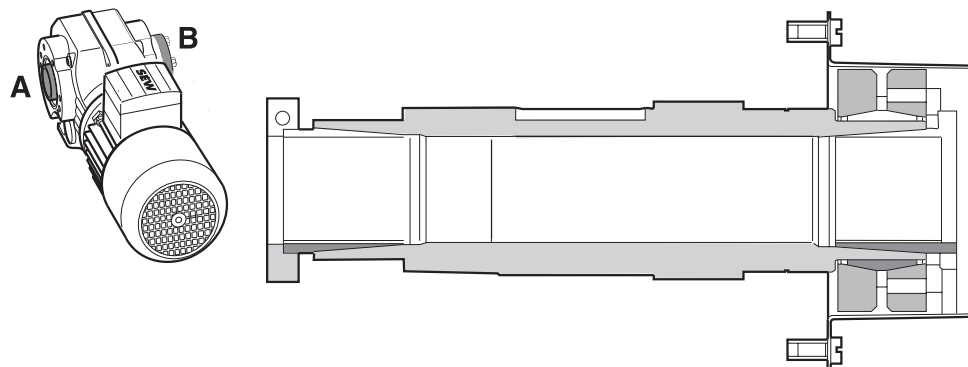

52310AXX

Figure 5: Design versions

Standard steel:

TorqLOC and TorqLOC Plus are available as standard steel types.

Stainless high-grade steel:

Both versions, TorqLOC and TorqLOC Plus, are also available as a stainless high-grade steel type. The high-grade steel type is initially only available on request and may have an extended delivery time. Individual sizes of the high-grade steel type may have a reduced torque capacity. Contact the corresponding technical departments when selecting the gear units.

4.3 Materials used

	Hollow shaft	Bronze bushing	Steel bushing	Clamping ring	Shrink disc	Cover
Standard version	C45	CuSn12-C-GC	C45	C45	34CrNiMo6	X5CrNi18-10
Stainless type	X39CrMO17-1		X17CrNiMo13-4 (1.4057)			



The conical bushing opposite the shrink disc connection is made of bronze in both types. The material pairing of bronze and steel between the bushing and the hollow shaft or customer's shaft largely eliminates fretting corrosion. This means the material selection improves the disassembly characteristics. The conical bushing on the shrink disc end must be made of steel because bronze would not be able to cope with the clamping forces required for transmitting the torque.

4.4 NOCO-FLUID®

As standard, SEW-EURODRIVE supplies NOCO-FLUID® corrosion protection and lubricant with every hollow shaft gear unit. Use NOCO-FLUID® when installing hollow shaft gear units. This will reduce any possible fretting corrosion and facilitate possible removal later on.

Furthermore, NOCO-FLUID® is also suitable for protecting machined metal surfaces which do not have corrosion protection. These include parts of shaft ends or flanges, for example. You can also order larger containers of NOCO-FLUID® from SEW-EURODRIVE.

Starting from the summer 2003 sales period, NOCO-FLUID® will be certified as a food industry oil in accordance with USDA-H1. You can tell that NOCO-FLUID® is a food industry oil due to the USDA-H1 identification on its packaging.



Figure 6: NOCO-FLUID®

52468AXX



4.5 Part numbers for rated diameter, standard type

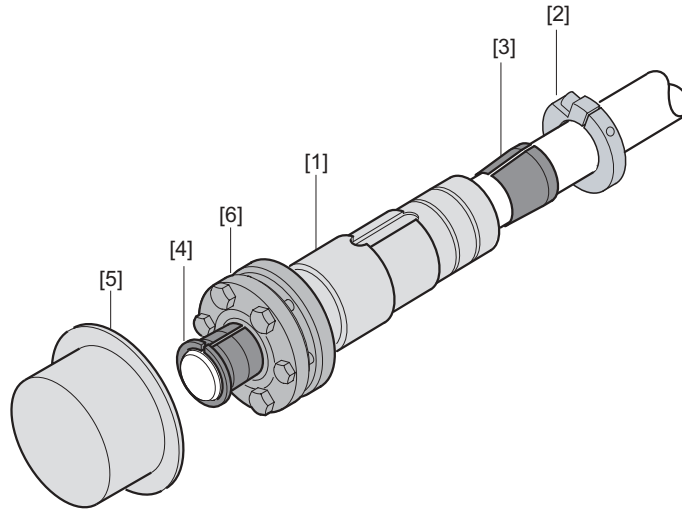

Figure 7: TorqLOC

52469AXX

TorqLOC standard steel type

Rated diameter [mm]	Gear unit type			Hollow shaft standard TorqLOC Plus [1]	Clamping ring [2]	Bronze bushing [3]	Steel bushing [4]	Clamping set complete	Cover complete [5]	Shrink disc [6]
	KT	FT	ST							
20			37	0643 713 3 0643 834 2	0643 726 5	0643 941 1	0643 950 0	1067 800 X	0644 476 8	0643 957 8
30	37	37	47	0643 715 X 0643 835 0	0643 728 1	0643 942 X	0643 951 9	1067 801 8	0643 584 X	0643 958 6
35	47	47	57	0643 716 8 0643 836 9	0643 729 X	0643 943 8	0643 952 7	1067 802 6	0643 585 8	0643 959 4
40	57	57		0643 717 6 0643 837 7	0643 730 3	0643 944 6	0643 953 5	1067 803 4	0643 586 6	0643 960 8
	67	67		0643 718 4 0643 838 5						
			67	0643 719 2 0643 839 3						
50	77	77		0643 720 6 0643 840 7	0643 732 X	0643 947 0	0643 954 3	1067 804 2	0643 587 4	0643 961 6
			77	0643 721 4 0643 841 5						
65	87	87		0643 722 2 0643 842 3	0643 733 8	0643 948 9	0643 955 1	1067 805 0	0643 588 2	0643 962 4
			87	0643 723 0 0643 843 1						
75	97	97		0643 724 9 0643 844 X	0643 734 6	0643 949 7	0643 956 X	1067 806 9	0643 589 0	0643 963 2
			97	0643 725 7 0643 845 8						



4.6 Part numbers for rated diameter, stainless type

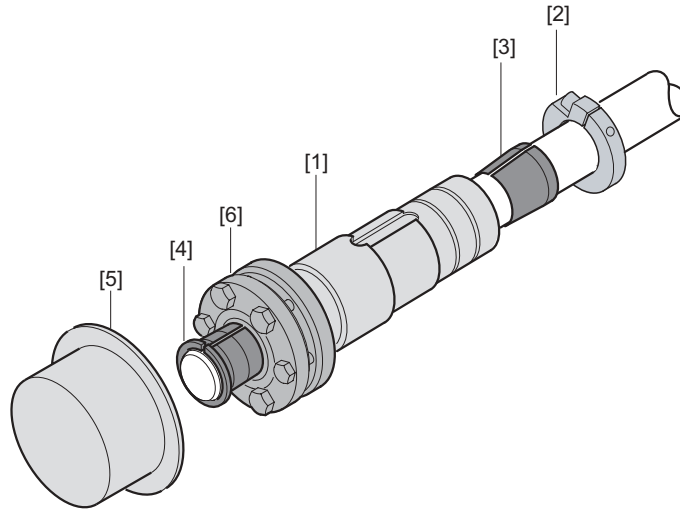

Figure 8: TorqLOC

52469AXX

**TorqLOC type
(stainless) →
Optional type**

Rated diameter [mm]	Gear unit type			Hollow shaft standard TorqLOC Plus [1]	Clamping ring [2]	Bronze bushing [3]	Steel bushing [4]	Clamping set complete	Cover complete [5]	Shrink disc [6]
	KT	FT	ST							
20			37	0643 846 6 0643 858 X	0643 934 9	0643 941 1	0643 877 6	1067 807 7	0644 476 8	0643 964 0
30	37	37	47	0643 847 4 0643 859 8	0643 935 7	0643 942 X	0643 885 7	1067 808 5	0643 584 X	0643 965 9
35	47	47	57	0643 848 2 0643 860 1	0643 936 5	0643 943 8	0643 895 4	1067 809 3	0643 585 8	0643 966 7
40	57	57		0643 849 0 0643 861 X	0643 937 3	0643 944 6	0643 905 5	1067 810 7	0643 586 6	0643 967 5
	67	67		0643 850 4 0643 862 8						
			67	0643 851 2 0643 863 6						
50	77	77		0643 852 0 0643 864 4	0643 938 1	0643 947 0	0643 915 2	1067 811 5	0643 587 4	0643 968 3
			77	0643 853 9 0643 865 2						
65	87	87		0643 854 7 0643 866 0	0643 939 X	0643 948 9	0643 925 X	1067 812 3	0643 588 2	0643 969 1
			87	0643 855 5 0643 867 9						
75	97	97		0643 856 3 0643 868 7	0643 940 3	0643 949 7	0643 933 0	1067 813 1	0643 589 0	0643 970 5
			97	0643 857 1 0643 869 5						



4.7 Different diameters

Only standard shaft diameters are specified in the catalog at present. Different diameters are available on request or must be produced to order. The following table provides information about possible maximum and minimum shaft diameters. A corresponding special design request must be submitted if necessary.

Gear units	Type	Standard shaft diameter	Minimum shaft diameter	Maximum shaft diameter
			[mm]	
Helical-worm gear units	ST37	20	15	20
	ST47	30	25	32
	ST57	35	30	37
	ST67	40	35	42
	ST77	50	40	52
	ST87	65	48	67
	ST97	75	60	78
Parallel shaft helical gear units	FT37	30	25	32
	FT47	35	30	37
	FT57	40	35	42
	FT67	40	35	42
	FT77	50	40	52
	FT87	65	48	67
	FT97	75	60	78
Helical-bevel gear units	KT37	30	25	32
	KT47	35	30	37
	KT57	40	35	42
	KT67	40	35	42
	KT77	50	40	52
	KT87	65	48	67
	KT97	75	60	78



4.8 Bushings in mm dimensions

Apart from the rated diameters, some additional bushings with other diameters are already available. These can be ordered in addition to or instead of the rated diameter by quoting their part numbers.

TorqLOC standard steel type

Gear unit type			[mm]		[mm]		[mm]		[mm]	
KT	FT	ST	Bronze	Steel	Bronze	Steel	Bronze	Steel	Bronze	Steel
		37		20		19		16		
			643 941 1	643 950 0	643 738 9	643 782 6	643 736 2	643780 X		
37	37	47		30						
			643 942 X	643 951 9						
47	47	57		35		30				
			643 943 8	643 952 7	643 748 6	643 792 3				
57	57			40		38		35		
67	67	67	643 944 6	643 953 5	643 762 1	643 806 7	643 760 5	643 804 0		
77	77	77		51		50				
			643 770 2	643 814 8	643 947 0	643 954 3				
87	87	87		65		62		60	51	
			643 948 9	643 955 1	643 774 5	643 818 0	643 629 3	643 628 5	643 772 9	643 816 4
97	97	97		75		70		62		
			643 949 7	643 956 X	643 777 X	643 821 0	643 776 1	643 820 2		

TorqLOC stainless type (NIRO)

→ Optional type

Gear unit type			[mm]		[mm]		[mm]		[mm]	
KT	FT	ST	Bronze	Steel	Bronze	Steel	Bronze	Steel	Bronze	Steel
		37		20		19		16		
			643 941 1	643 877 6	643 738 9	643 875 X	643736 2	643 871 7		
37	37	47		30						
			643 942 X	643 885 7						
47	47	57		35		30				
			643 943 8	643 895 4	643 748 6	643 887 3				
57	57			40		38		35		
67	67	67	643 944 6	643 905 5	643 762 1	643 901 2	643 760 5	643 897 0		
77	77	77		51		50				
			643 770 2	643 913 6	643 947 0	643 915 2				
87	87	87		65		62		60		51
			643 948 9	643 925 X	643 774 5	643 923 3	643 629 3	643 587 4	643 772 9	643 919 5
97	97	97		75		70		62		
			643 949 7	643 933 0	643 777 X	643 929 2	643 776 1	643 927 6		

The stainless steel type of individual sizes may result in the gear units having a reduced torque capacity. Please contact SEW-EURODRIVE in this case.



4.9 Bushings in inch dimensions

A series of diameters has already been produced especially for the American market. The bushings are in stock at SEW USA and can be order as required.

TorqLOC standard steel type

Gear unit type			[inch]	[mm]	[inch]	[mm]	[inch]	[mm]	[inch]	[mm]
KT	FT	ST	Bronze	Steel	Bronze	Steel	Bronze	Steel	Bronze	Steel
		37			0,625	15,875	0,6875	17,463	0,75	19,05
					643 736 2	643 780 X	643 737 0	643 781 8	643 738 9	643 782 6
37	37	47			1	25,4	1,1875	30,163	1,25	31,75
					643 744 3	643 788 5	643 745 1	643 789 3	643 739 7	643 790 7
47	47	57	1.1875	30.1625	1.25	31.75	1.375	34.925	1.4375	36.5125
			643 748 6	643 792 3	643 749 4	643 793 1	643 750 8	643 794 X	643 751 6	643 795
57	57		1.375	34.925	1.4375	36.5125	1.5	38.1	1.625	41.275
67	67	67	643 760 5	643 804 0	643 761 3	643 805 9	643 762 1	643 806 7	643 763 X	643 807 5
77	77	77	1.625	41.275	1.75	44.45	1.9375	49.213	2	50.8
			643 767 2	643 811 3	643 768 0	643 812 1	643 769 9	643 813 X	643 770 2	643 814 8
87	87	87	1.9375	49.2125	2	50.8	2.375	60.325	2.4375	61.9125
			643 740 0	643 741 9	643 772 9	643 816 4	643 773 7	643 817 2	643 774 5	643 818 0
97	97	97			2.4375	61.9125	2.75	69.85	2.9375	74.6125
					643 776 1	643 820 2	643 777 X	643 821 0	643 778 8	643 822 9

TorqLOC stainless type (NIRO)

→ Optional type

Gear unit type			[inch]	[mm]	[inch]	[mm]	[inch]	[mm]	[inch]	[mm]
KT	FT	ST	Bronze	Steel	Bronze	Steel	Bronze	Steel	Bronze	Steel
		37			0.625	15.875	0.6875	17.463	0.75	19.05
					643 736 2	643 871 7	643 737 0	643 873 3	643 738 9	643 875 X
37	37	47			1	25.4	1.1875	30.163	1.25	31.75
					643 744 3	643 879 2	643 745 1	643 881 4	643 739 7	643 883 0
47	47	57	1.1875	30.1625	1.25	31.75	1.375	34.925	1.4375	36.5125
			643 748 6	643 887 3	643 749 4	643 889 X	643 750 8	643 891 1	643 751 6	643 893 X
57	57		1.375	34.925	1.4375	36.5125	1.5	38.1	1.625	41.275
			643 760 5	643 897 0	643 761 3	643 899 7	643 762 1	643 901 2	643 763 X	643 903 9
77	77	77	1.625	41.275	1.75	44.45	1.9375	49.213	2	50.8
			643 767 2	643 907 1	643 768 0	643 909 8	643 769 9	643 911 X	643 770 2	643 913 6
87	87	87	1.9375	49.2125	2	50.8	2.375	60.325	2.4375	61.9125
			643 740 0	643 917 9	643 772 9	643 919 5	643 773 7	643 921 7	643 774 5	643 923 3
97	97	97			2.4375	61.9125	2.75	69.85	2.9375	74.6125
					643 776 1	643 927 6	643 777 X	643 929 2	643 778 8	643 931 4



5 Installation notes

5.1 Delivery condition

The gearmotors are delivered with the TorqLOC hollow shaft already installed in the gear unit. The clamping ring, shrink disc and the two conical bushings are supplied with the drive as separate assembly parts. The cover is installed and is painted together with the drive.



Figure 9: TorqLOC delivery condition

52546AXX

5.2 Use in existing systems

The following points must be checked and/or observed if a new TorqLOC drive is used as a replacement for an existing drive with a key or a conventional shrink disc:

- Is the existing input shaft end long enough for the TorqLOC shaft? A slightly longer axial distance is required than in conventional shaft mounted gear units.
- Can the previous torque arm continue to be used? Design changes may be required.

Basically, it is possible to convert an existing drive to a TorqLOC clamping joint. However, you should bear in mind that TorqLOC hollow shafts are not identical to the hollow shafts used with the standard shrink disc. That means the gear unit has to be completely stripped down as part of the conversion and reassembled with the new TorqLOC shaft and all the TorqLOC assembly parts.



5.3 Assembly instructions

Anzugsdrehmomente Klemmring
tightening torques retaining ring
Couples de serrage de l'anneau de serrage

Typ type Type		Drehmomente (Nm) torques Couples	
KT/FT	ST	nickelbeschichtet nickel plated avec couche de nickel	Edelstahl stainless steel Acier spécial
-	37	18	7.5
37	47	18	7.5
47	57	18	7.5
57,67	67	35	18
77	77	35	18
87	87	35	18
97	97	35	18



9.

10.

11.

12.

13.

14.

Anzugsdrehmomente Schrumpfscheibe
tightening torques shrink disc
Couples de serrage de la frette

Typ type Type	Drehmomente (Nm) torques Couples	Drehmomente (Nm)	
		nickelbeschichtet nickel plated avec couche de nickel	Edelstahl stainless steel Acier spécial
KT/FT	ST		
-	37	4.1	6.8
37	47	10	6.8
47	57	12	6.8
57,67	67	12	15
77	77	30	30
87	87	30	50
97	97	30	50

Abstandsmaß a (mm)
distance dimension a (mm)
Cote d' écartement a (mm)

Typ type Type	a min.	a max.
-	3.3	5.6
37	3.3	5.6
47	5.0	7.6
57,67	5.0	7.6
77	5.0	7.6
87	5.8	8.6
97	5.8	8.6

6 Applications

Shaft mounted gear units with TorqLOC clamping joints are particularly well suited for use as a drive unit for conveyor belts and as travel drives. In this case, the compact design of the right-angle gear units or parallel shaft helical gear units means they can be ideally integrated into the machine design.

Applications:

- Roller conveyers
- Belt conveyors
- Chain conveyors
- Trolleys
- Travelling gear
- ...

Configuring a shaft mounted gearmotor with TorqLOC is particularly beneficial in materials handling systems that need to have a high level of serviceability. As a result, using TorqLOC drives is very advantageous in industries in which machine downtime is extremely expensive.

Industrial sectors:



- Beverage industry
- Automotive industry
- Food industry
- ...

7 Clamping Joint for Bearings and Other Shaft/Hub Connections

Other shaft/hub connections with an increased tolerance adjustment are often also necessary to benefit from the advantage of using drawn shaft material for the customer's shaft.

SKF offers ConCentra bearing units that allow for using conventional shafts up to quality h9. Ground shafts are not required with these connections, as also with TorqLOC.



Figure 10: Bearing units

52522AXX

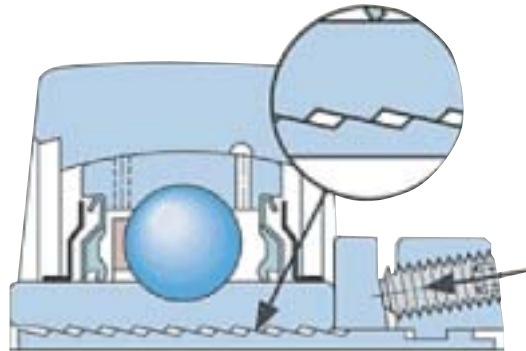

Figure 11: Bearing units

52523AXX

As well as the bearing units, ConCentra is also available as a shaft/hub connection for all other transmission elements. In this case, ConCentra is used as a connection element between the customer's shaft and the transmission element.

By using the ConCentra solution from SKF in conjunction with TorqLOC, customers can design an entire driveline using low-cost unmachined shafts.



8 Dimension sheets for gear units with TorqLOC clamping joint

8.1 CAD drawings

CAD drawings in various formats (dxf, dwg, sat...) can be generated online for every drive in DriveCAD.

Visit http://www.sew-eurodrive.de/english/06_software/index_software.htm to generate and download a corresponding file for any customer-specific drive.



8.2 Dimension sheet for helical-bevel gear units with TorqLOC (KT..)

33 001 01 03

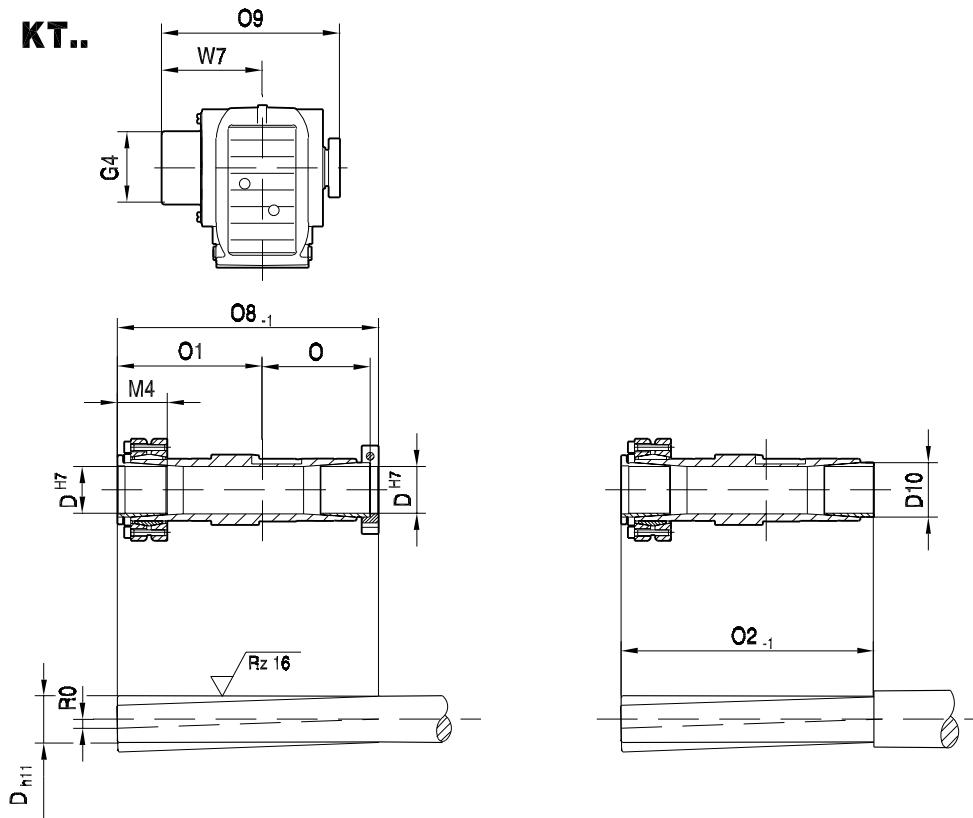

	D	G4	M4	O	O1	O8	O9	R0	W7	O2	D10
KT37	30	81	33	70	93	169	178	max. 0.129	102	163	37
KT47	35	89	37	87	113	206	211.5	max. 0.129	118.5	200	42
KT57	40	97	44	95	128	230.5	236	max. 0.157	133.5	223	48
KT67	40	97	44	102	134	243.5	249.5	max. 0.157	140	236	48
KT77	50	124	59	120	164	291.5	301	max. 0.157	173.5	284	60
KT87	65	165	66	136	189	334	340.5	max. 0.188	195.5	325	80
KT97	75	200	66	166	220	395	400.5	max. 0.188	225.5	386	89



8.3 Dimension sheet for parallel shaft helical gear units with TorqLOC (FT..)

42 003 01 03

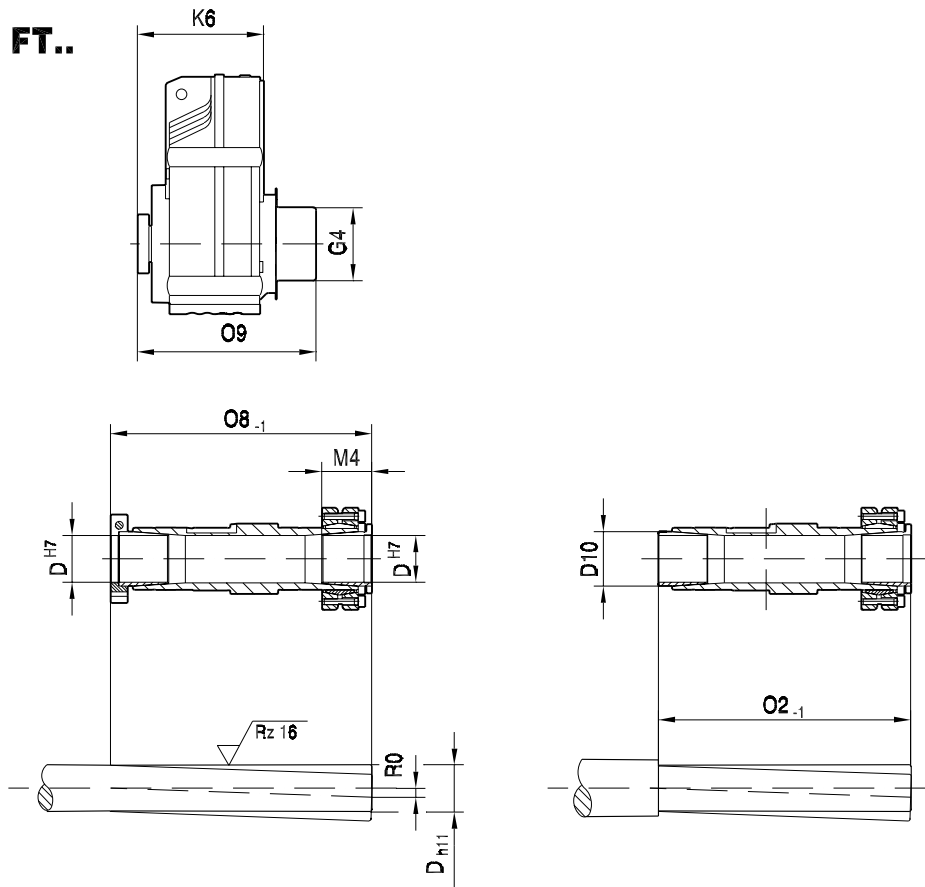

	D	G4	K6	O8	O9	M4	R0	O2	D10	
FT37	30	81	126	169	178	33	max. 0.129	163	37	max. DR63
FT47	35	89	151	206	211.5	37	max. 0.129	200	42	max. DT80
FT57	40	97	169	230.5	236	44	max. 0.157	223	48	max. DT80
FT67	40	97	180.5	243.5	249.5	44	max. 0.157	236	48	
FT77	50	124	214.5	291.5	301	59	max. 0.157	284	60	
FT87	65	165	263	334	340.5	66	max. 0.188	325	80	
FT97	75	200	299	395	400.5	66	max. 0.188	386	89	max. DV180



8.4 Dimension sheet for helical-worm gear units with TorqLOC (ST..)

02 001 01 03

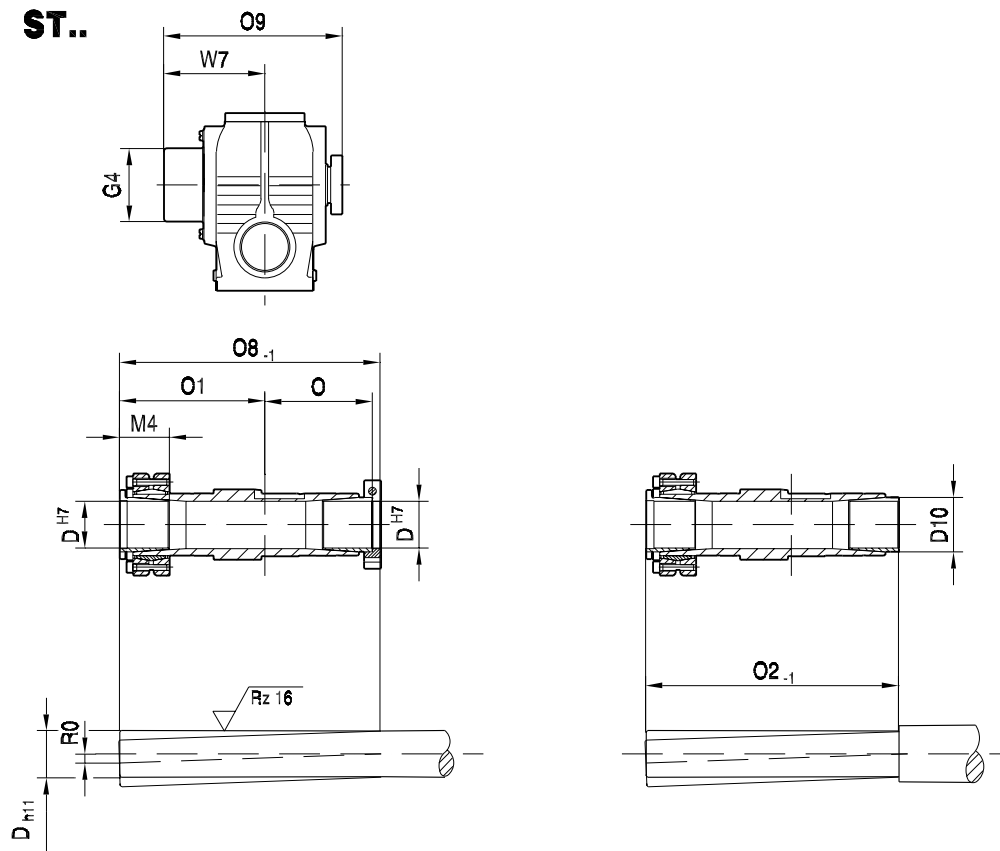

	D	G4	M4	O	O1	O8	O9	R0	W7	O2	D10
ST37	20	64	28	70	89	165	171	max. 0.129	95	159	24
ST47	30	81	33	70	93	169	178	max. 0.129	102	163	37
ST57	35	89	37	87	113	206	211.5	max. 0.129	118.5	200	42
ST67	40	97	44	96	128	231.5	237.5	max. 0.157	134	224	48
ST77	50	124	59	120	164	291.5	301	max. 0.157	173.5	284	60
ST87	65	165	66	141	191	341	349.5	max. 0.188	199.5	332	80
ST97	75	200	66	161	211	381	389.5	max. 0.188	219.5	372	89



9 Documentation

You can find more information about TorqLOC in the following publications:

- **Flyer**

Publication no. (German)	10566341
Publication no. (English)	10566341

- **GM2004 (not yet available)**

Publication no. (German)	11215402
Publication no. (English)	11215410

- **Gear unit operating instructions**

Publication no. (German)	11215704
Publication no. (English)	11215712

- **TorqLOC assembly instructions**

Publication no. (German)	11238801
Publication no. (English)	11238828

**10 Awards**

Readers of the American publication "Plant Engineering" have made their choice and awarded prizes for "Product of the Year 2002." The award is given to innovative products which lead to ground-breaking improvements at the production level. SEW-EURODRIVE received the "Silver Award" for TorqLOC.



06573AXX
Figure 12: "Silver Award" for
TorqLOC

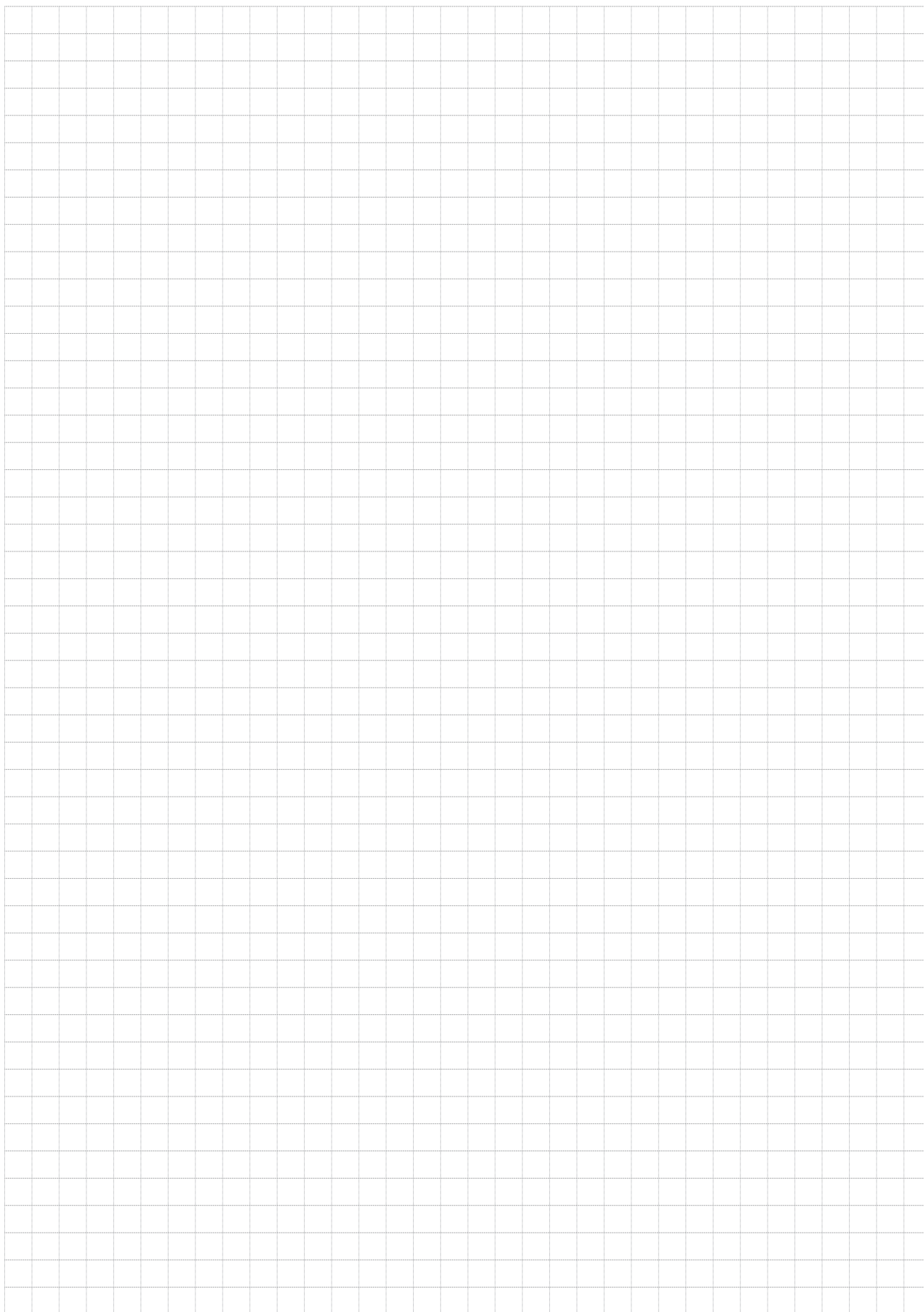

SEW-EURODRIVE GmbH & Co KG · P.O. Box 3023 · D-76642 Bruchsal/Germany
Phone +49 7251 75-0 · Fax +49 7251 75-1970
<http://www.sew-eurodrive.com> · sew@sew-eurodrive.com

SEW
EURODRIVE

